

1. Manual clamps – Standard range

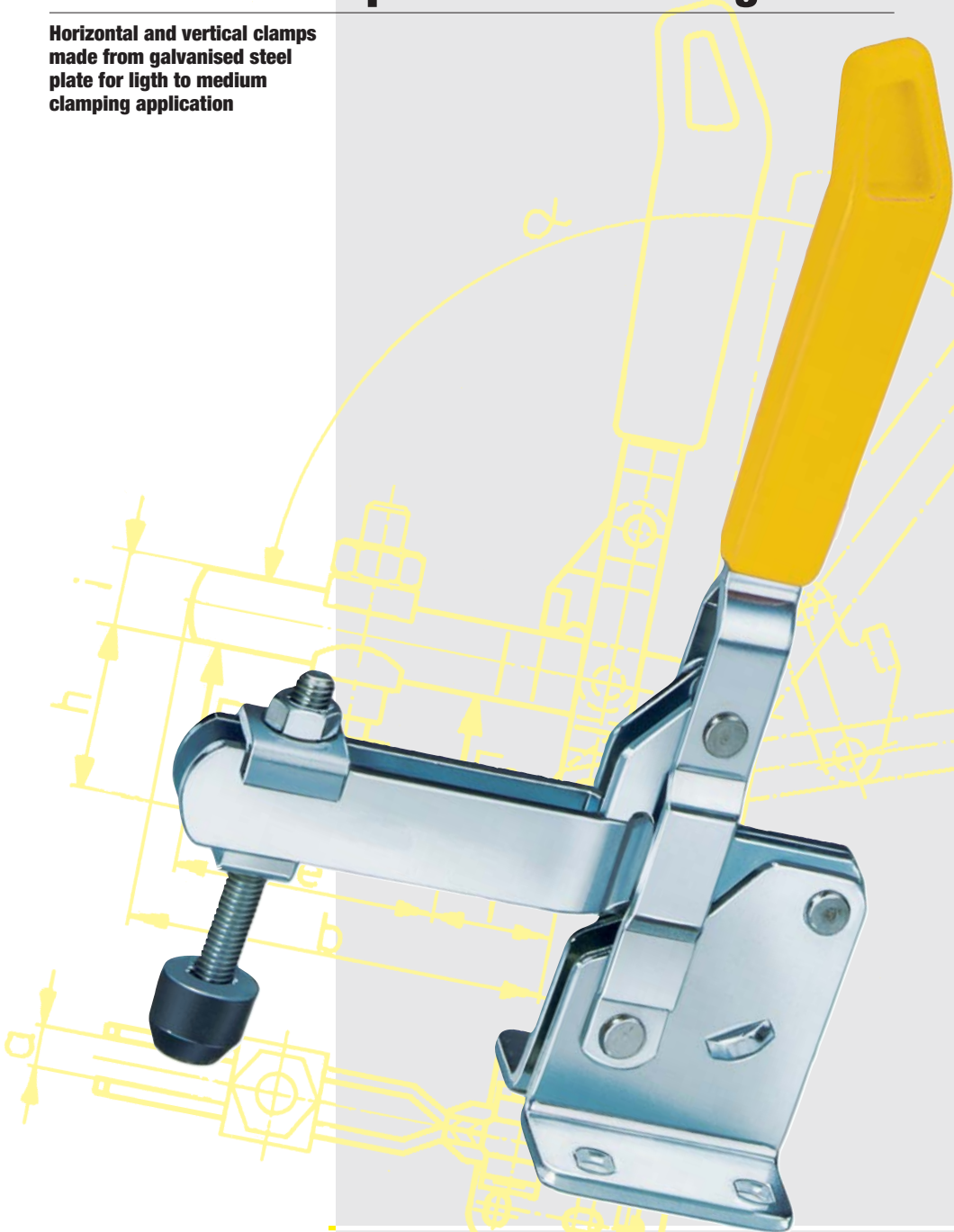

Horizontal and vertical clamps
made from galvanised steel
plate for light to medium
clamping application



Ексклюзивний дилер в Україні:

Роботікс Інженерія

Вул. Святошинська, 34
тел. (044) 707-16-16, 407-16-17
факс: (044) 407-18-30
www.robotics.kiev.ua

TÜNKERS® Maschinenbau GmbH · Am Rosenkoth 8 · DE-40880 Ratingen · Germany
Info-Telephone: +49 (0) 21 02 / 45 17-0 · Fax +49 (0) 21 02 / 44 68 08 · www.tuenkers.de

Clamping tools for professionals



Ergonomic plastic handle, mounted with secure press fit

High quality surface protection due to construction made from galvanised steel plate **optional stainless steel construction** for special applications with exposure to moisture / water

Long service life through rivet made from solid stainless steel and hardened bearing bushes

Two part clamp lever for rapid installation and dismantling of the clamping element



Option:
Safety latch „A“,
on request

Internal stop for a defined clamp lever position

Option:
Stainless steel „E“,
on request

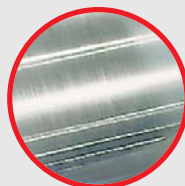

Ексклюзивний дилер в Україні:

Роботікс Інженерія

Вул. Святошинська, 34
тел. (044) 707-16-16, 407-16-17
факс: (044) 407-18-30
www.robotics.kiev.ua

Technical modifications reserved. 10/00

TÜNKERS® Maschinenbau GmbH · Am Rosenkoth 8 · DE-40880 Ratingen · Germany
Info-Telephone: +49 (0) 21 02 / 45 17-0 · Fax +49 (0) 21 02 / 44 68 08 · www.tuenkers.de

The TÜNKER[®] product code



The simple type designations simplify the ordering



An overview of the types

- T2 → standard manual clamps, vertical or horizontal design
- T3 → locking clamps
- T5 → industrial manual clamps, vertical or modular design
- T6 → push and pull clamps

Order code for manual clamps

Example:

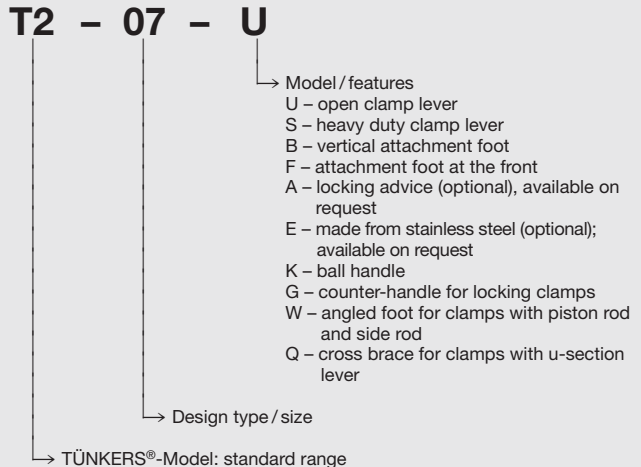

Ексклюзивний дилер в Україні:

Роботікс Інженерія

ВУА, Святошинська, 34
тел.: (044) 707-16-16, 407-16-17
факс: (044) 407-18-30
www.robotics.kiev.ua

Vertical clamp T 2-.. U



U-arm standard base

Option: Stainless steel version „E“
version with safety latch „A“
on request



Delivery: with accessories to mount setscrew

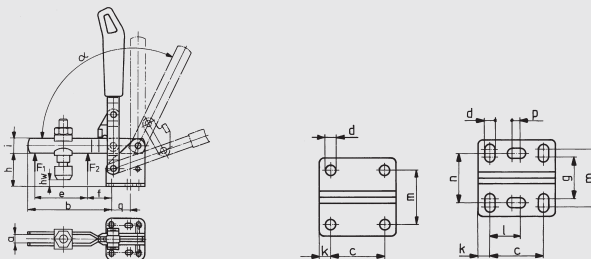

Type	Clamping force F1 [kN]	F2 [kN]	heigh	width	hw	clamp screw	weight g
T 2-01 U	0,8	1,1	105	60	-4÷ 3	M 5x 30	105
T 2-02 U	1,0	1,2	144	82	-3÷ 6	M 6x 35	175
T 2-07 U	1,8	2,5	206	112	0÷ 12	M 8x 45	335
T 2-10 U	2,0	3,0	230	140	-8÷ 21	M 8x 65	630
T 2-47 U	3,0	5,0	300	195	10÷ 34	M12x 80	1480
T 2-67 U	3,5	5,5	356	230	27÷157	M12x110	2200

Type	a	b	c	d	e	f	g	h	i	k	l	m	n	o	q	α
T 2-01 U	5	38	16,0	4,5	19	14	-	20	10	5,5	-	24	-	-	12	95°
T 2-02 U	6	51	20,0	5,5	25	20	24,0	25	12	5,0	12,5	30	27	-	13	105°
T 2-07 U	8	80	19,0	6,5	43	27	-	34	18	7,5	-	32	-	-	16	105°
T 2-10 U	10	100	32,0	8,5	61	30	-	42	20	13,0	-	45	-	-	22	105°
T 2-47 U	14	142	45,0	8,5	88	40	45,0	55	25	9,5	31,5	50	45	5	31	115°
T 2-67 U	14	165	50,0	10,5	90	55	-	85	30	12,5	-	70	-	-	35	105°

Vertical clamp T 2-.. UB



U-arm vertical base

Option: Stainless steel version „E“
version with safety latch „A“
auf Anfrage



Delivery: with accessories to mount setscrew

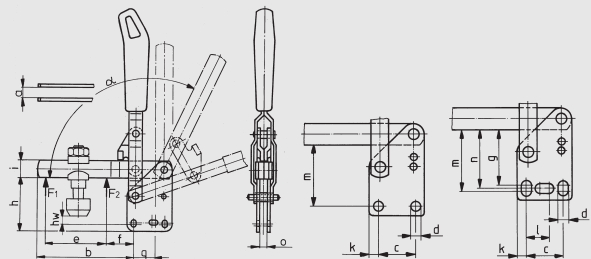

Type	Clamping force F1 [kN]	F2 [kN]	heigh	width	hw	clamp screw	weight g
T 2-01 UB	0,8	1,1	115	60	2÷ 9	M 5x 30	105
T 2-02 UB	1,0	1,2	157	82	5÷14	M 6x 35	175
T 2-07 UB	1,8	2,5	220	112	8÷20	M 8x 45	335
T 2-10 UB	2,0	3,0	252	140	5÷33	M 8x 65	630
T 2-47 UB	3,0	5,0	321	195	22÷45	M12x 80	1480
T 2-67 UB	3,5	5,5	372	230	46÷76	M12x110	2200

Type	a	b	c	d	e	f	g	h	i	k	l	m	n	o	q	α
T 2-01 UB	5	38	16	4,5	19	14	-	31	10	5,5	-	26,5	-	5,0	12	95°
T 2-02 UB	6	51	20	5,5	25	20	30	38	12	5,0	12,5	33,0	31,5	5,5	13	105°
T 2-07 UB	8	80	19	6,5	43	27	-	48	18	7,5	-	42,0	-	6,0	16	105°
T 2-10 UB	10	100	32	8,5	61	30	-	65	20	13,0	-	55,5	-	8,0	22	105°
T 2-47 UB	14	142	45	8,5	88	40	64	76	25	9,5	31,5	66,5	64,0	10,0	31	115°
T 2-67 UB	14	165	50	10,5	90	55	-	116	30	12,5	-	104,0	-	10,0	35	105°

Ексклюзивний дилер в Україні:

Роботікс Інженерія

Вул. Святошинська, 34
тел. (044) 707-16-16, 407-16-17
факс: (044)407-18-30
www.robotixs.kiev.ua

TÜNKERS® Maschinenbau GmbH · Am Rosenkoth 8 · DE-40880 Ratingen · Germany
Info-Telephone: +49 (0) 21 02 / 45 17-0 · Fax +49 (0) 21 02 / 44 68 08 · www.tuenkers.de

Vertical clamp T 2-.. S



solid arm standard base

Option: stainless steel version „E“
version with safety latch „A“
on request

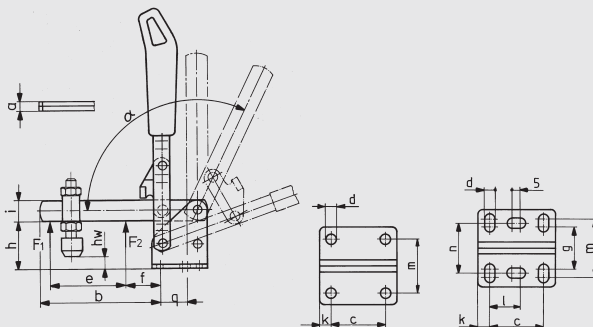

Type	Clamping force		heigh	width	hw	clamp screw	weight g
	F1 [kN]	F2 [kN]					
T 2-07 S	1,8	2,5	206	112	0÷12	M 8x 45	340
T 2-10 S	2,0	3,0	230	140	-8÷21	M 8x 65	585
T 2-47 S	3,0	5,0	300	195	10÷34	M12x 80	1480
T 2-67 S	3,5	5,5	356	230	27÷57	M12x110	2200

Type	a	b	c	d	e	f	g	h	i	k	l	m	n	o	q	α
T 2-07 S	6	81	19	6,5	43	27	-	34	18	7,5	-	32	-	-	16	105°
T 2-10 S	8	101	32	8,5	61	30	-	42	20	13,0	-	45	-	-	22	105°
T 2-47 S	10	143	45	8,5	88	40	45	55	25	9,5	31,5	50	45	5	31	115°
T 2-67 S	10	167	50	10,5	90	55	-	85	30	12,5	-	70	-	-	35	105°

Vertical clamp T 2-.. SB



solid arm vertical base

Option: stainless steel version „E“
version with safety latch „A“
on request

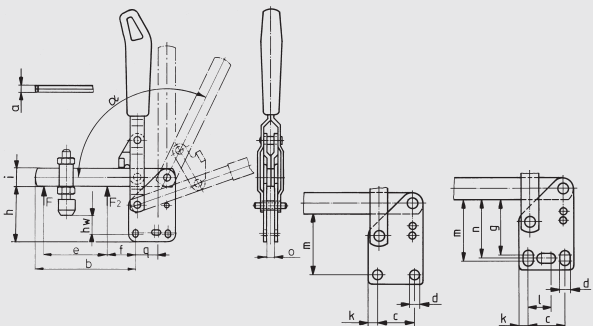

Type	Clamping force		heigh	width	hw	clamp screw	weight g
	F1 [kN]	F2 [kN]					
T 2-07 SB	1,8	2,5	220	112	8÷20	M 8x 45	400
T 2-10 SB	2,0	3,0	252	140	5÷33	M 8x 65	585
T 2-47 SB	3,0	5,0	321	195	22÷45	M12x 80	1480
T 2-67 SB	3,5	5,5	356	230	46÷76	M12x110	2200

Type	a	b	c	d	e	f	g	h	i	k	l	m	n	o	q	α
T 2-07 SB	6	81	19	6,5	43	27	-	48	18	7,5	-	42,0	-	6	16	105°
T 2-10 SB	8	101	32	8,5	61	30	-	65	20	13,0	-	55,5	-	8	22	105°
T 2-47 SB	10	143	45	8,5	88	40	64	76	25	9,5	31,5	66,5	64	10	31	115°
T 2-67 SB	10	167	50	10,5	90	55	-	116	30	12,5	-	104,0	-	10	35	105°

Ексклюзивний дилер в Україні:

Роботікс Інженерія

Вул. Свєтлошинська, 34
тел. (044) 707-16-16, 407-16-17
факс: (044) 407-18-30
www.robotics.kiev.ua

TÜNKERS® Maschinenbau GmbH · Am Rosenkoth 8 · DE-40880 Ratingen · Germany
Info-Telephone: +49 (0) 21 02/45 17-0 · Fax +49 (0) 21 02/44 68 08 · www.tuenkers.de

Vertical clamp T 2-.. UF



U-arm front mounting

Option: stainless steel version „E“
version with safety latch „A“
on request



Delivery: with accessories to mount setscrew

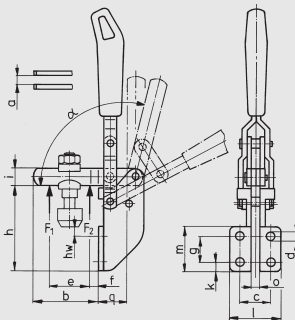

Type	Clamping force F1 [kN] F2 [kN]		height	width	hw	clamp screw	weight g
T 2-07 UF	1,0	1,2	180	76	2÷11	M6x35	220
T 2-10 UF	1,8	2,5	243	112	6÷18	M8x45	400

Type	a	b	c	d	e	f	g	h	i	k	l	m	o	q	α
T 2-07 UF	6	40	25,5	5,5	25	9	20	61	12	6,0	37,0	32	5	24	105°
T 2-10 UF	8	65	28,5	6,5	43	11	24	71	18	7,0	42,5	38	6	31	105°

Horizontal clamp T 2-.. U



U-arm standard base

Option: stainless steel version „E“
version with safety latch „A“
on request



Ексклюзивний дилер в Україні:

Роботікс Інженерія

Вул. Святошинська, 34
тел. (044) 707-16-16, 407-16-17
факс: (044) 407-18-30
www.robotixs.kiev.ua

Delivery: with accessories to mount setscrew

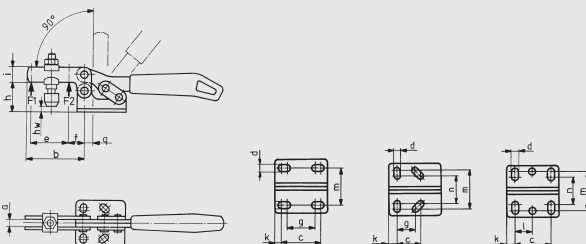

Type	Clamping force F1 [kN] F2 [kN]		height	width	hw	clamp screw	weight g
T 2-05 U	0,25	0,40	23	86	-5÷ 2	M4x25	35
T 2-13 U	0,80	1,10	30	130	-4÷ 3	M5x30	105
T 2-17 U	1,00	1,20	44	176	-3÷ 6	M6x35	185
T 2-27 U	1,80	2,50	48	221	-1÷11	M8x45	320
T 2-37 U	2,00	3,00	74	293	-6÷23	M8x65	700
T 2-45 U	3,00	5,00	71	338	-1÷25	M8x65	1080

Type	a	b	c	d	e	f	g	h	i	k	l	m	n	q
T 2-05 U	4	26	16,0	4,6	11	10	11,2	15	7	5,0	-	15,6/16,0	-	2
T 2-13 U	5	40	15,0	4,8	26	11	13,0	20	10	5,5	-	22,0	18	5
T 2-17 U	6	64	26,0	5,5	35	22	-	25	13	6,0	12,7	29,0	20	0
T 2-27 U	8	72	25,5	6,5	44	22	-	33	15	7,0	-	29,0	23	8
T 2-37 U	10	111	41,0	8,5	66	34	-	44	20	8,0	20,5	43,0	29	1
T 2-45 U	10	121	41,5	8,5	78	30	41,5	46	25	12,5	-	41,5	-	9

Technical modifications reserved. 10/00

TUNKERS® Maschinenbau GmbH · Am Rosenkoth 8 · DE-40880 Ratingen · Germany
Info-Telephone: +49 (0) 21 02/45 17-0 · Fax +49 (0) 21 02/44 68 08 · www.tuenkers.de

Horizontal clamp T 2-.. UB



U-arm vertical base

Option: stainless steel version „E“
version with safety latch „A“
on request

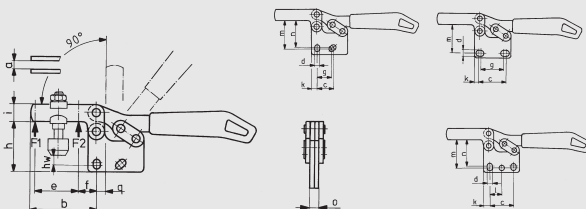

Type	Clamping force F1 [kN]	F2 [kN]	heigh	width	hw	clamp screw	weight g
T 2-05 UB	0,25	0,40	33,0	86	0÷ 7	M4x25	35
T 2-13 UB	0,80	1,10	42,0	130	3÷10	M5x30	105
T 2-17 UB	1,00	1,20	59,0	176	7÷16	M6x35	185
T 2-27 UB	1,80	2,50	63,5	221	8÷20	M8x45	320
T 2-37 UB	2,00	3,00	96,0	293	9÷38	M8x65	700
T 2-45 UB	3,00	5,00	91,5	338	13÷37	M8x65	1080

Type	a	b	c	d	e	f	g	h	i	k	l	m	n	o	q
T 2-05 UB	4	26	16,0	4,6	11	10	11,2	24	7	5,0	-	20	-	3	2
T 2-13 UB	5	40	15,0	4,8	26	11	13,0	32	10	5,5	-	27	25	5	5
T 2-17 UB	6	64	26,0	5,5	35	22	-	40	13	6,0	12,7	35	31	5	0
T 2-27 UB	8	72	25,5	6,5	44	22	-	48	15	7,0	-	42	39	6	8
T 2-37 UB	10	111	41,0	8,5	66	34	-	66	20	8,0	20,5	59	52	8	1
T 2-45 UB	10	121	41,5	8,5	78	30	41,5	66	25	12,5	-	58	-	10	9

Delivery: with accessories to mount setscrew

Horizontal clamp T 2-.. S



solid arm standard base

Option: stainless steel version „E“
version with safety latch „A“
on request

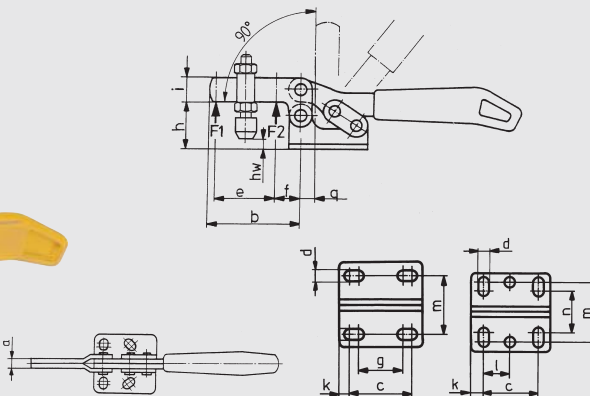

Type	Clamping force F1 [kN]	F2 [kN]	heigh	width	hw	clamp screw	weight g
T 2-15 S	1,00	1,20	44	176	-3÷6	M 6x35	185
T 2-45 S	3,00	5,00	71	338	1÷25	M12x80	1080

Type	a	b	c	d	e	f	g	h	i	k	l	m	n	q
T 2-15 S	5	64	26,0	5,5	35	22	-	25	13	6,0	12,7	29,0	20	0
T 2-45 S	10	121	41,5	8,5	78	30	41,5	46	25	12,5	-	41,5	-	9

Ексклюзивний дилер в Україні:

Роботікс Інженерія

Вул. Святошинська, 34
тел. (044) 707-16-16, 407-16-17
факс: (044) 407-16-30
www.robotixs.kiev.ua

Technical modifications reserved. 10/00

TÜNKERS® Maschinenbau GmbH · Am Rosenkoth 8 · DE-40880 Ratingen · Germany
Info-Telephone: +49 (0) 21 02/45 17-0 · Fax +49 (0) 21 02/44 68 08 · www.tuenkers.de

Horizontal clamp T 2-.. UF



U-arm front mounting

Option: stainless steel version „E“
version with safety latch „A“
on request

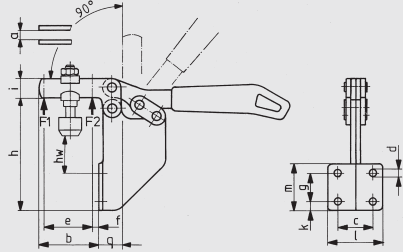

Type	Clamping force F1 [kN]	Clamping force F2 [kN]	height	width	hw	clamp screw	weight g
T 2-17 UF	1,0	1,2	88,5	176	20÷29	M6x35	245
T 2-27 UF	1,8	2,5	86,0	221	6÷18	M8x45	390

Type	a	b	c	d	e	f	g	h	i	k	l	m	q
T 2-17 UF	6	52	25,5	5,5	35	10	20	74	13	6	37,0	32	12
T 2-27 UF	8	58	28,5	6,5	40	8	24	71	15	7	42,5	38	23

Delivery: with accessories to mount setscrew

Setscrew T 2-.. A



with neoprene cover

tempored
tenside strength class 8.8
galvanized

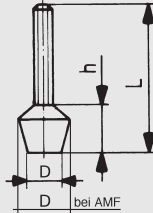

Type	size	diameter	height h	length L	weight g
T2-AS 5x30	M 5x30	13	10	38	8
T2-AS 6x35	M 6x35	16	13	45	12
T2-AS 8x35	M 8x35	21	16	48	25
T2-AS 8x50	M 8x50	21	16	63	30
T2-AS 8x65	M 8x65	21	16	78	35
T2-AS 12x50	M12x50	31	24	70	70
T2-AS 12x80	M12x80	31	24	100	90

Ексклюзивний дилер в Україні:

Роботікс Інженерія

Вул. Святошинська, 34
тел. (044) 707-16-16, 407-16-17
факс: (044) 407-18-30
www.robotics.kiev.ua

Technical modifications reserved. 10/00

TÜNKERS® Maschinenbau GmbH · Am Rosenkoth 8 · DE-40880 Ratingen · Germany
Info-Telephone: +49 (0) 21 02 / 45 17-0 · Fax +49 (0) 21 02 / 44 68 08 · www.tuenkers.de

Hook clamp T 3-..



Standard base

Option: stainless steel version „E“
version with safety latch „A“
on request

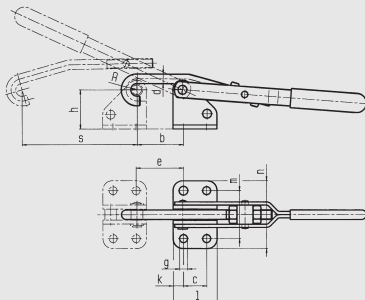

Type	Clamping force [kN]	Adjustment (mm)	heigh	width	weigh g
T 3-30	2,0	5	33	130	100
T 3-51	3,0	12	36	230	270
T 3-81	5,0	12	70	308	850

Type	b	c	d	e	g	h	k	l	m	n	R	s
T 3-30	36-41	19	5,3	36,5-41,5	4,5	22,5	6	31	28	41	4,5	45
T 3-51	67-79	19	7,1	74,5-86,5	5,5	23,0	13	40	32-35	46	5,5	98
T 3-81	58-70	29	12,0	58,5-70,5	11,0	49,0	13	55	60	88	8,0	144

Latch bracket T 3-.. G



for hook clamp Typ T 3-...

galvanized, bushes case hardened,
rivet of stainless steel

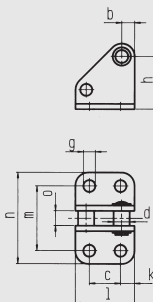

Type	heigh	width	weigh g
T 3-30 G	29	31	40
T 3-51 G	29	40	70
T 3-81 G	61	55	320

Type	b	c	d	g	h	k	l	m	n	o
T 3-30 G	6	19	8	4,5	22,5	6	31	28	41	6,8
T 3-51 G	6	19	10	5,5	23,0	13	40	32-35	46	10,8
T 3-81 G	12	29	15	11,0	49,0	13	55	60	89	13,7

Ексклюзивний дилер в Україні:

Роботікс Інженерія

Вул. Святошинська, 34
тел. (044) 707-16-16, 407-16-17
факс: (044) 407-16-30
www.robotixs.kiev.ua

Technical modifications reserved. 10/00

TÜNKERS® Maschinenbau GmbH · Am Rosenkoth 8 · DE-40880 Ratingen · Germany
Info-Telephone: +49 (0) 21 02 / 45 17-0 · Fax +49 (0) 21 02 / 44 68 08 · www.tuenkers.de

Push-Pull clamp T 6-..



Standard version front mounting

Option: stainless steel version „E“
version with safety latch „A“
on request

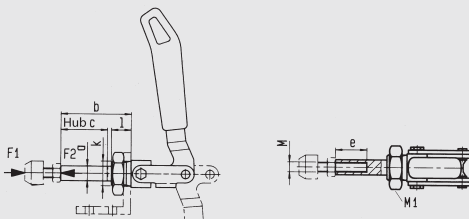

Type	Clamping force		height	width	clamp screw	weight g
	F1 [kN]	F2 [kN]				
T 6-02	1,0	1,0	85	70	M 6x25	130
T 6-04	2,5	2,5	135	110	M 8x35	320
T 6-24	4,0	4,0	120	175	M12x50	1200

Type	Ø a	b	c	e	k	l	M
T 6-02	10	14-35	21	15	M16x1,5	12	M 6
T 6-04	12	18-56	38	25	M20x1,5	16	M 8
T 6-24	16	25-92	67	35	M24x1,5	22	M12

Delivery: with accessories to mount setscrew

Mounting bracket T 6-.. W



for Push-Pull clamp Type T6-...

to be fixed with four screws

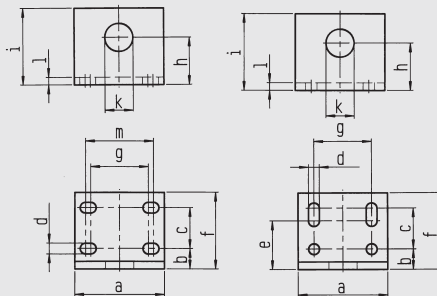

Type	a	f	i	weight g
T 6-02 W	60	40	40	170
T 6-04 W	65	44	50	260

Type	b	c	d	e	g	h	k	l	m
T 6-02 W	11,0	18	6,5	22	40	24	16,2	5	-
T 6-04 W	14,5	19	6,7	-	41	33	20,2	6	-

Ексклюзивний дилер в Україні:

Роботікс Інженерія

Вул. Святошинська, 34
тел. (044) 707-16-16, 407-16-17
факс: (044)407-18-30
www.robotics.kiev.ua

Technical modifications reserved. 10/00

TÜNKERS® Maschinenbau GmbH · Am Rosenkoth 8 · DE-40880 Ratingen · Germany
Info-Telephone: +49 (0) 21 02 / 45 17-0 · Fax +49 (0) 21 02 / 44 68 08 · www.tuenkers.de